



**sahinler**  
METAL MAKİNE ENDÜSTRİ A.Ş.

5794

2006

RM1270x90 2.5mm

## USER'S MANUAL MODEL RM MOTORIZED PLATE BENDING MACHINE

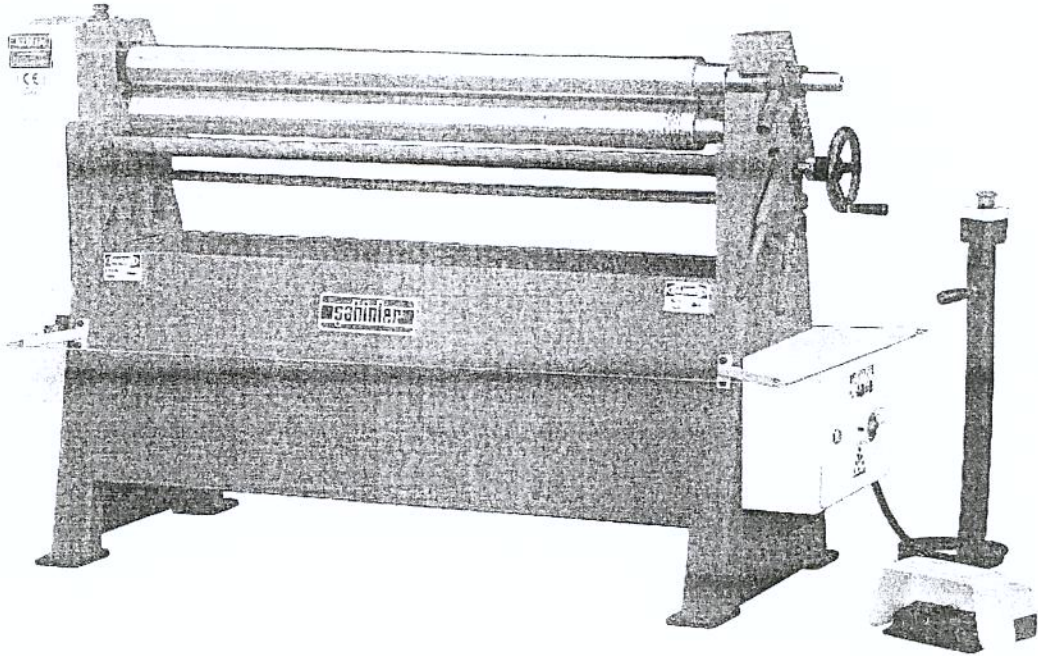

İzmir Yolu 22.km Mümin Gencoğlu Cad. 16285 BURSA / TURKEY

Tel: +90-224-4700158 (6 lines pbx)

Fax: +90-224-4700770

Web: [www.sahinlermetal.com](http://www.sahinlermetal.com)

Email: [info@sahinlermetal.com](mailto:info@sahinlermetal.com)

Spare parts & service: [service@sahinlermetal.com](mailto:service@sahinlermetal.com)



**ŞAHİNLER**  
METAL MAKİNE ENDÜSTRİ A.Ş.



## CE DECLARATION

We as

**ŞAHİNLER METAL MAKİNE END. A.Ş.**  
İzmir Yolu 22.km  
Mümin Gençoğlu Caddesi  
Bursa / TÜRKİYE

confirm that the machine

RM 1270x90

Serial Number : 220669  
Production Year : 2004

complies with

EC MACHINES DIRECTIVE 89 / 392 / EWG / CEE  
replaced with EC-Directives 91 / 368 / EWG and  
90 / 44 - EWG and  
93 / 68 / CEE  
EC-Low Voltage 73 / 23 / EWG  
EC - Noise Level Directives 86 / 188 / EWG  
EC-Directives EMV 89 / 336 / EWG

and the machine also harmonized with the standards

DIN EN 60204 Part 1

Name : Orhan ŞAHİN  
Position : General Director

BURSA, on 07 EYLÜL 2004

**ŞAHİNLER**  
Metal Makine Endüstri A.Ş.  
Mrk: Havat... 16180 BURSA  
Fab: İzmir... Mümin Gençoğlu Cd  
Tel: 470 01 58-63 Fax: 470 01 70 BURSA  
Çekirge V.D. - 798 000 4677

<b>CONTENTS</b>	<b>Page</b>
<i>General Notes</i>	1 – 2
<i>General Warranty Terms</i>	3
<i>Transport and Lifting</i>	4
<i>Technical Properties</i>	5
<i>Main Dimensions</i>	6
<i>Adjustment for Parallelism</i>	7
<i>Electrical Connections</i>	8
<i>Start-up Instructions</i>	9 – 10
<i>Safety Directives</i>	11 – 15
<i>Bending Operations</i>	16 – 21
<i>Opening the Top Roll</i>	22
<i>Maintenance</i>	23
<i>Parts List of the RM Model</i>	24
<i>Main Parts Schema</i>	25
<i>Electrical Schemas</i>	







### TRANSPORT AND LIFTING OF THE MACHINE

The machine weight is approximately. Use necessary cranes and lift as shown. Please take extra care during lifting and moving. If necessary consult with specialized companies for lifting.

### APPROX MACHINE WEIGHT

Model	Weight
RM 1050x90	450Kg
RM 1270x90	570Kg
RM 1550x90	600Kg
RM 2050x95	800Kg

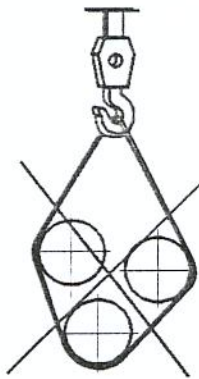

**FALSE**

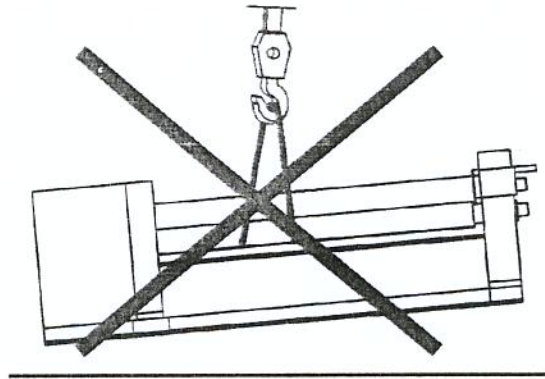

**FALSE**

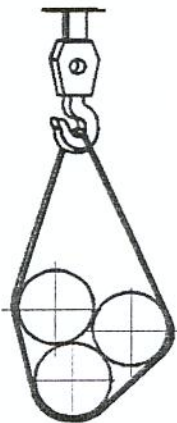

**TRUE**

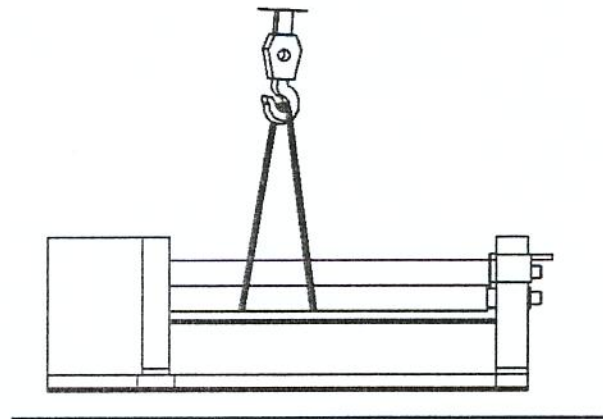

**TRUE**

### OPENING THE PACKAGE

If any visible damage exist on the machine when you receive the machine immediately informs the dealer or manufacturer. Also never forget to state the visible damage on transport documents.

The packing material is completely safe and do not consist any environmentally dangerous articles. However they must be kept out reach of children as some nylon products in packing may cause suffocation if used as a toy etc.



## TECHNICAL PROPERTIES

The RM Model Motorized Benders have these specifications:

### TECHNICAL SPECIFICATIONS AND STANDARD EQUIPMENTS

- > Two rolls powered by a single Gearbox and gear system
- > SAE 1050 Quality certificated steel rolls with high tensile strength
- > Cast iron main frame
- > Mobile Control Panel
- > Precision Bending with Brake Motor
- > Conical bending device
- > Worldwide available components used in production( Telemecanique, Siemens for electrics )
- > User manual book
- > Built according to EC safety directives  
( CE – Mark )

<b>MODEL: RM Technical Properties</b>					
<b>MODEL</b>		<b>RM1050x90</b>	<b>RM1270x90</b>	<b>RM1550x90</b>	<b>RM2050x95</b>
<b>Bending capacity</b>	mm	3.0	2.5	2.0	1.5
<b>Roll Diameters</b>	∅ mm	90	90	90	95
<b>Roll Speed</b>	rpm	6	6	6	6
<b>Motor Power</b>	Kw	1.5	1.5	1.5	1.5
<b>Dimensions</b>	mm	1650x750x1170	1900x750x1170	2150x750x1170	2650x750x1170
<b>Useful length</b>	mm	1050	1270	1550	2050
<b>Weight</b>	kg	450	570	600	800



**Note :** Machine dimensions are approximate

### OPTIONAL ACCESSORIES

- > Induction hardened rolls
- > Motorized Back Roll Adjustment



**Warning:** Do not feed profiles having a higher thickness than specified for the capacity of the machine. Do not feed more than one piece at a time. Do not use the machine for any other job the one for which it has been designed.

**MODEL RM MAIN DIMENSIONS**

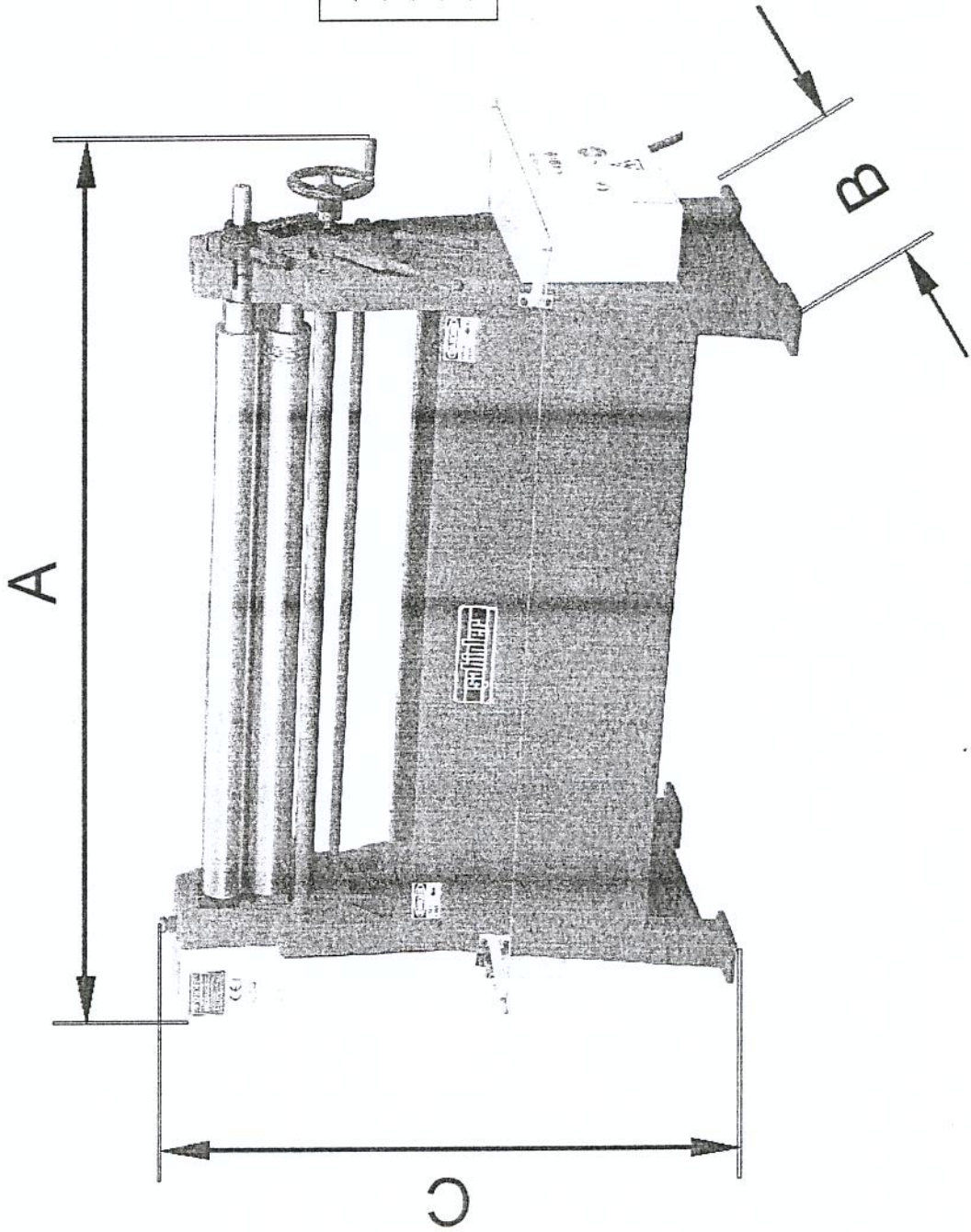

MODEL	A	B	C
RM 1050x90	1650	750	1170
RM 1270x90	1900	750	1170
RM 1550x90	2150	750	1170
RM 2050x90	2650	750	1170

## ADJUSTMENT FOR PARALLELISM

Check parallelism of the rolls before bending with a round bar.

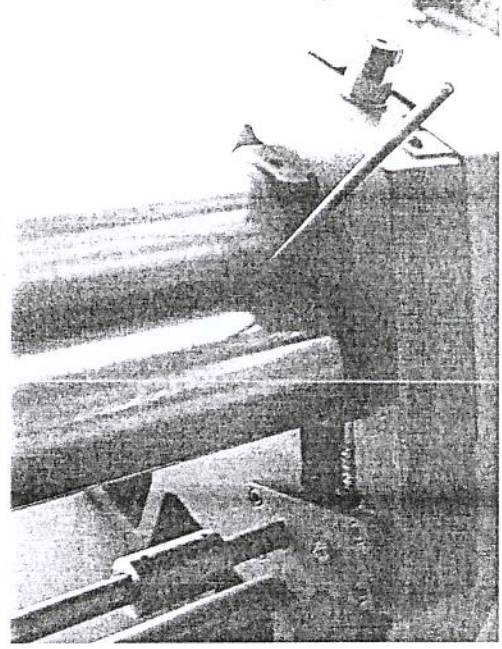
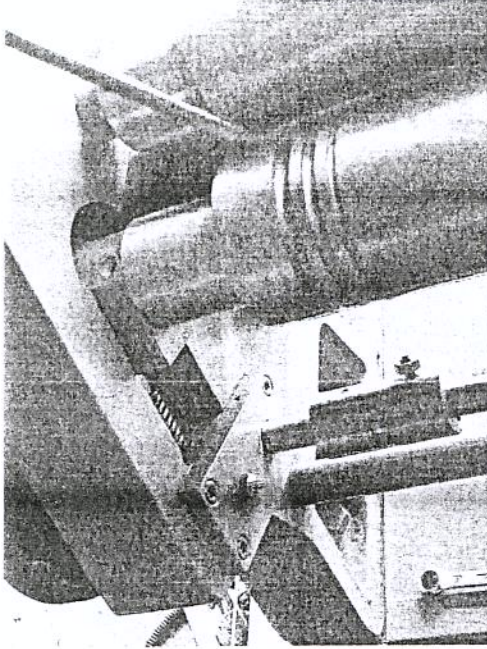

**Note:** After placing the machine make sure all areas of the machine is flat and check parallelism of the machine periodically by a water gauge.

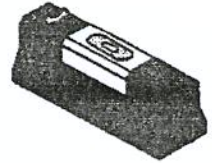













### EXPLANATION FOR SAFETY SWITCH

The machine has been equipped with a security switch and wire for the operators safety. When the safety wire is pushed it pulls the below shown ring this act as emergency stop and stops all machine activity.

To restart pull the blue knob (shown by ① in fig.1) while pulling the safety wire when engaged you should see green (shown by ② in fig.2) line under the blue knob. Now you can restart the machine from control panel.

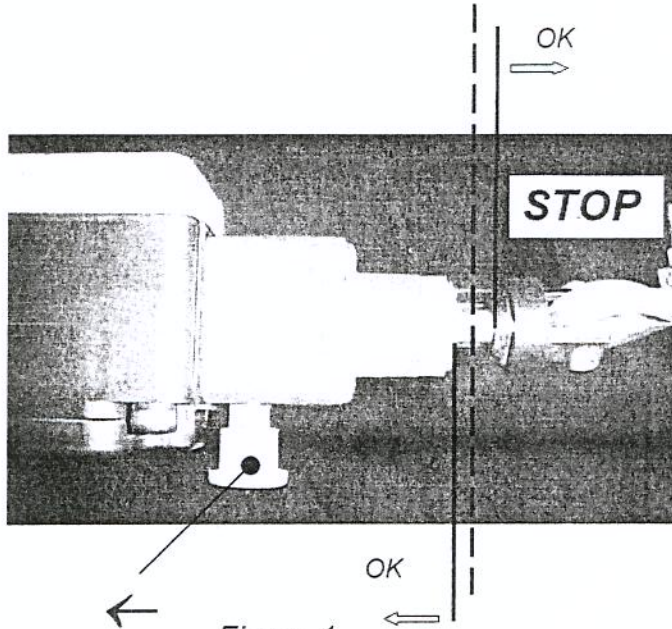
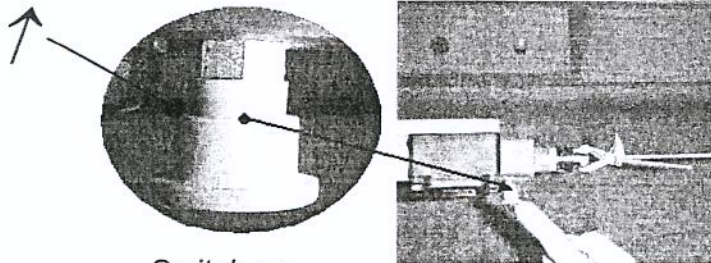

Figure 1

Safety switch's on and off positions as given below.



Switch on position

Figure 2

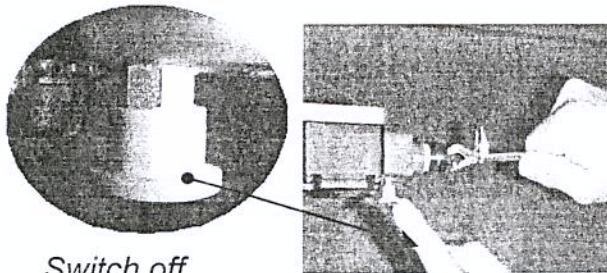

Switch off position

Figure 3



The safety wire comes unassembled for packing reasons and must be assembled by the customer as shown above to completely surround the machine

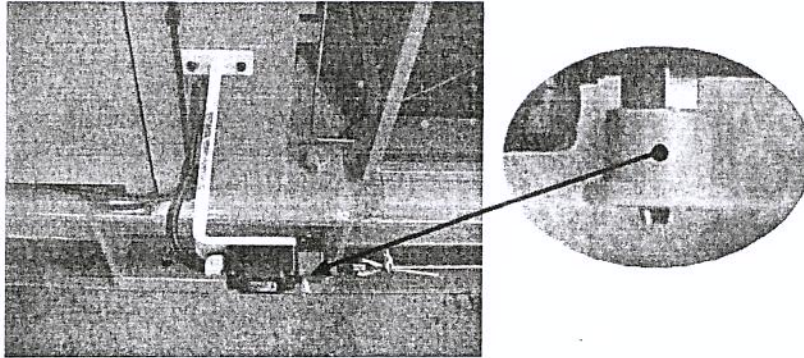

Figure 4



**Attention:**

The safety wire is an important safety measure and must never be removed while the machine is setup. It should be only removed for transport purposes.

While assembling it is important to fit the wire to the safety switch lock securely as shown below.

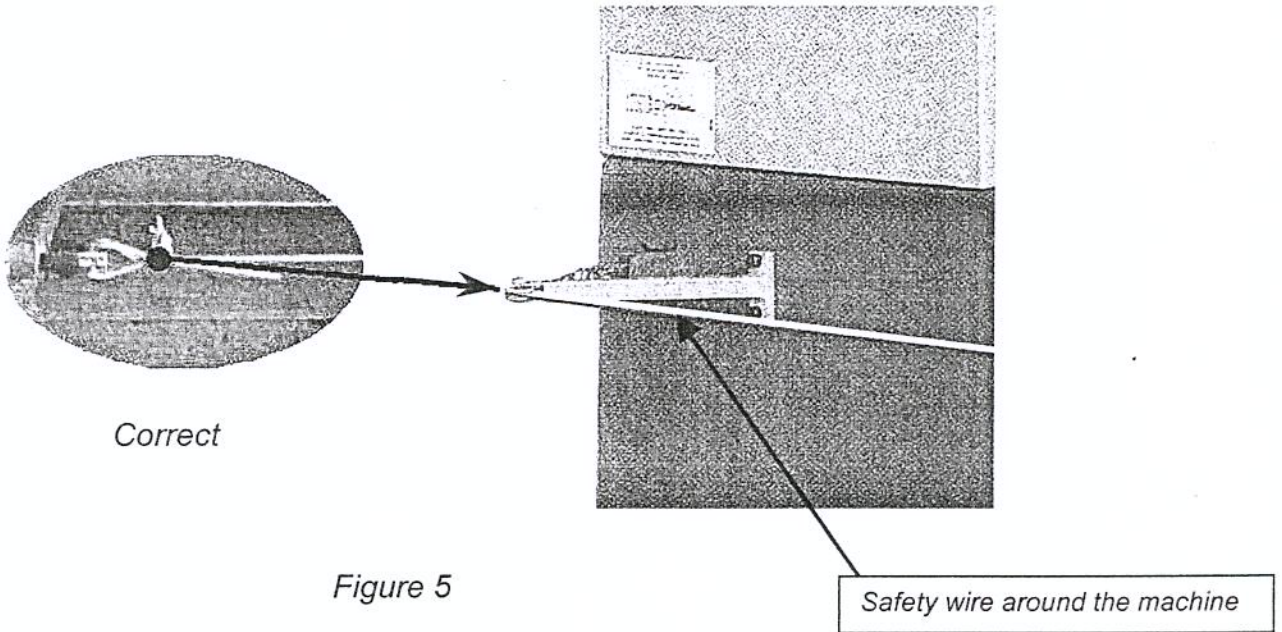

Figure 5





## Sheet Bending Position

**Figure 1**

Top roll and lower roll in a flat position.

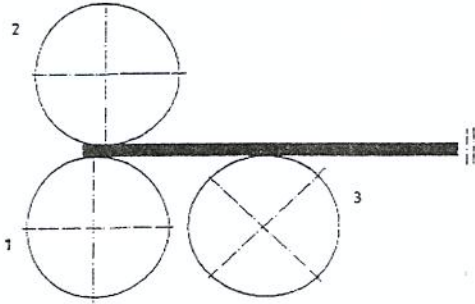

**Figure 1**

**Figure 2**

Move the back roll up to complete the pre-bending

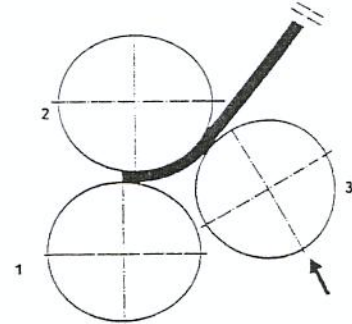

**Figure 2**

**Figure 3**

Reverse the sheet and place for second pre-bending.

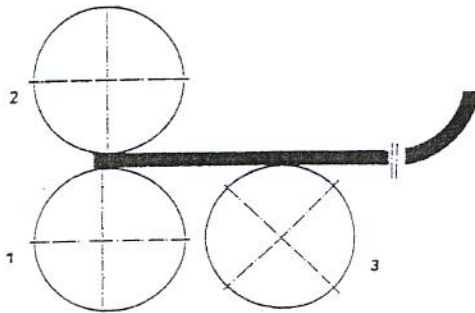

**Figure 3**

**Figure 4**

Move the back roll up to complete Pre-bending

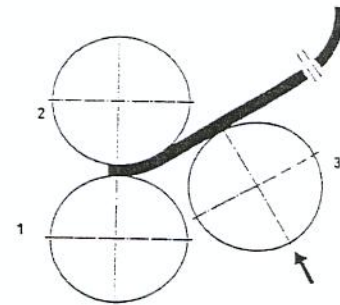

**Figure 4**

**Figure 5**

Roll until required diameter is achieved.

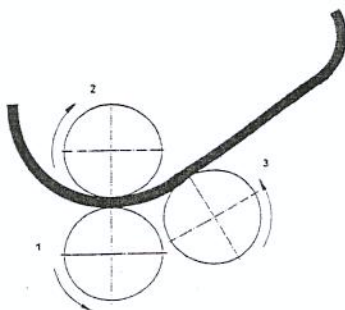

**Figure 5**

**Figure 6**

Finish operation shown as below. .

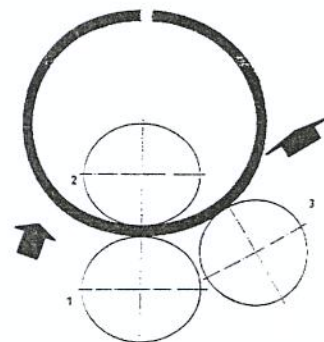

**Figure 6**





**Note:** That the material will progressively harden with each pass.



**Note:** If you are working with stainless steel it is important to finish the job in a few passes. Because stainless steel is a work hardening material.



**Attention :** Be sure to clean any oil or grease on the rolls before operation.

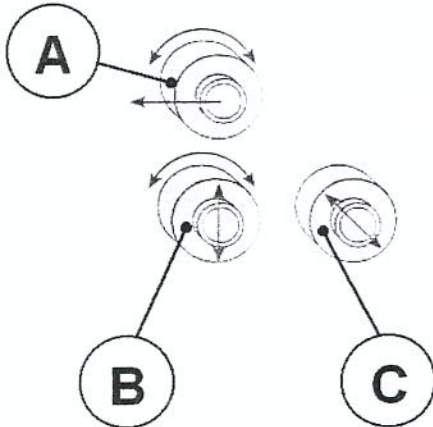

- A. Top Roll
- B. Lower Roll ( Pinch Roll )
- C. Back Roll ( Bend Roll )



### CONICAL BENDING

Conical bending is more difficult than normal bending. So machine capacity must be reduced to %30 - %50 to determine conical bending capacity of the machine. Also machine must be prepared for conical bending operation as shown.

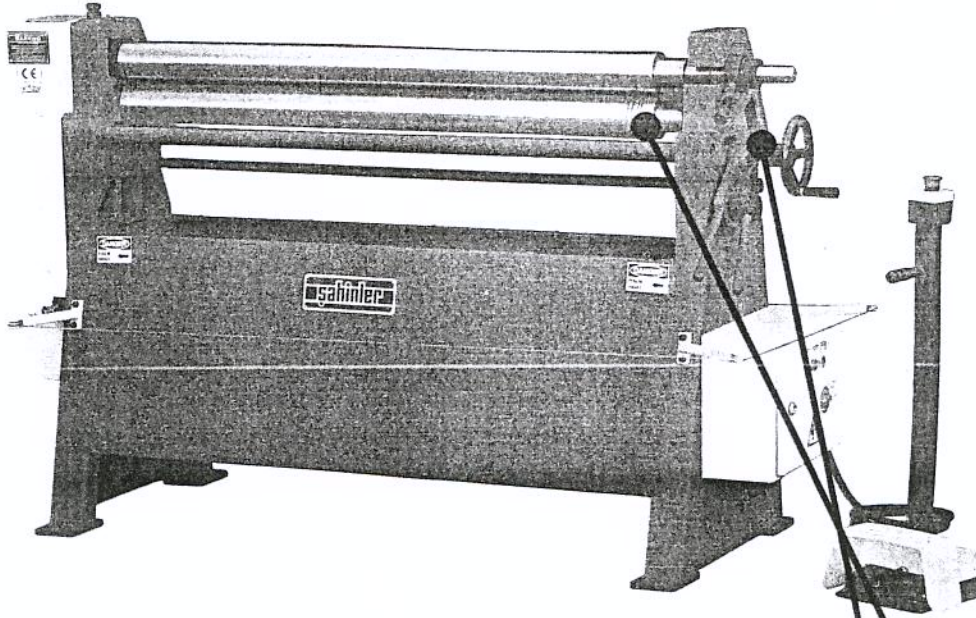

Figure-1

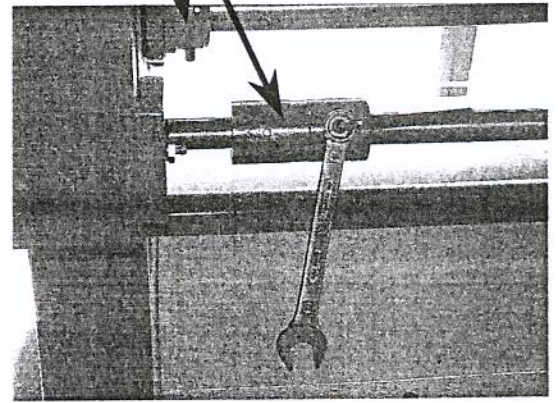

Figure-2



**Note:** When bending conical the overall max. thickness capacity decreases by 30 - 50 %

#### Figure -1

Move both lower roll and back roll to the lowest position as shown above

#### Figure-2

Remove couplings by a hand tool on the drop end side so that only that side of the rolls will move when you use the handwheels. When you move the handwheels the rolls will move only in one side so that you can make conical bending. You can now put the material by the conical bending device and start bending

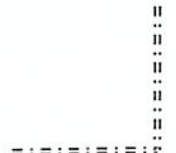



## CONICAL BENDING DEVICE

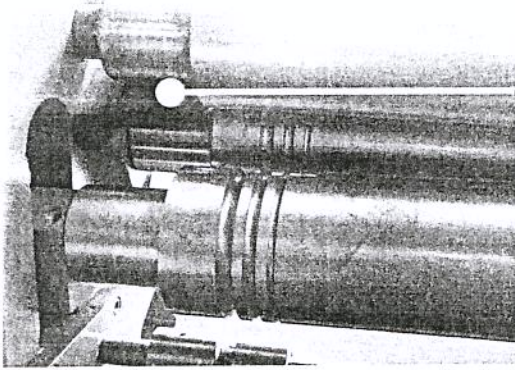

Conical Bending Device

Conical Bending Device as shown above has been designed and hardened for supporting the part of the plate held against it during the conical bending operation.

### **Normal Bending after Conical Bending**

You **must** adjust the rolls back to parallel position after working conical. To do this simply :

- Move the drop end side rolls to the lowest position by the handwheels.
- Connect the couplings on Figure-2 above
- The machine should be parallel to work normal bending





### Counter Balance System ;

There is a counter balance bolt located on top of the top roll bushing. This is to prevent the top roll from inclining down too much, when opened.

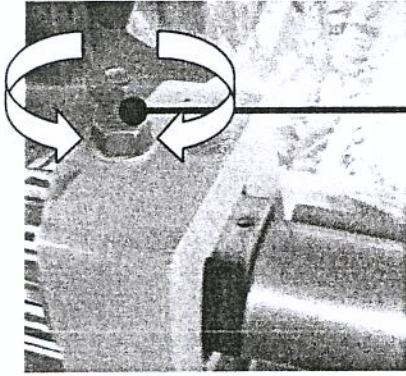

Balance bolt

- Tighten CW to counter more.
- Loosen CCW to decrease counter force.

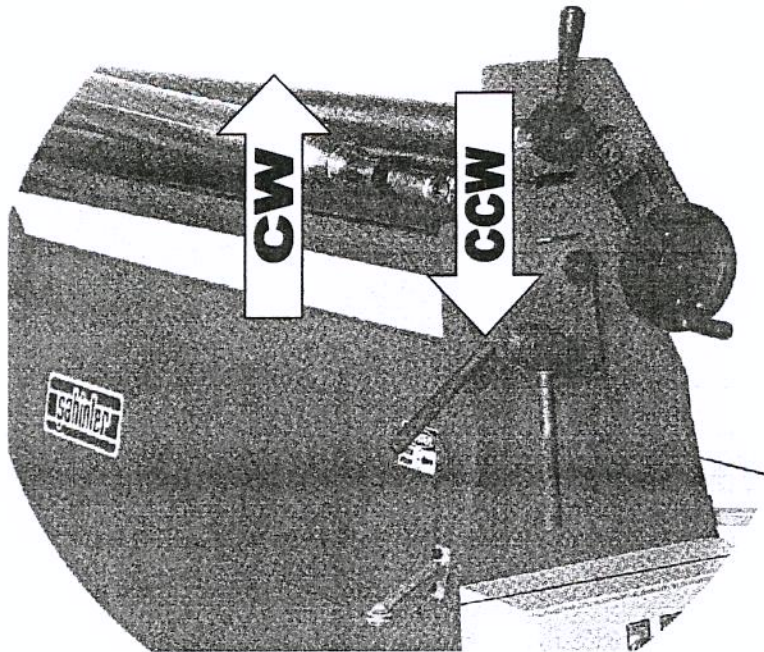

## OPENING THE TOP ROLL

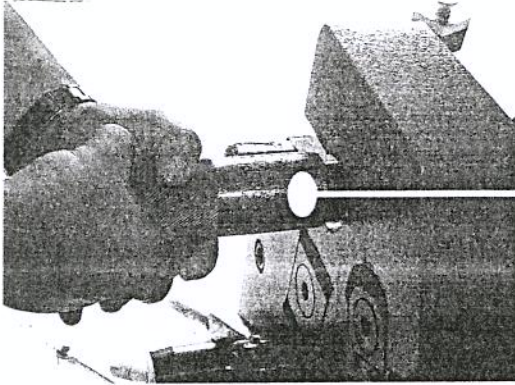

Mechanical  
Lock

Figure - 1

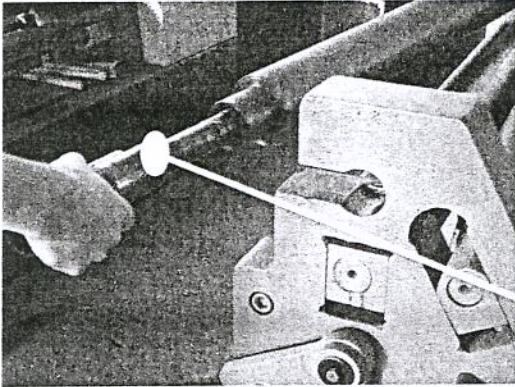

Clear  
Position

Figure - 2

Opening the top roll is easy and safe. Once the top roll is open the machine will not function.

1. Move the handle as far as you can and see that the roll can move in the housing (Figure - 1)
2. Pull the top roll out (Figure - 2)
3. Reverse above steps to close the top roll and make sure the mechanical spring is secure.



### Warning:

Do **NOT** modify this safety device. **NEVER** operate any function of the machine while the top roll is open.



## MAINTENANCE

### PERIODIC CONTROLS

The rolls of the machine must **NEVER** be greased or lubricated. Because, then the rolls will slip the material and will not bend. Always keep the rolls clean and free from grease or any lubricant. Also make sure that the material is free from grease and dirt.

These points must be greased periodically at least once a month or more if daily usage exceeds 8 hours a day. Note that some of these points are actually inside the machine cover and the front cover must be removed in order to reach them. Any standard commercial grease can be used for lubrication.

NUMBER	PERIOD	WHAT TO DO
1- Moving Parts	Once a month	Grease
2- Bushing	Twice a year	Oil

The reduction gearbox of the machine is inside the front cover and is maintenance free. Only you should control it periodically and tighten the bolts fixing it to motor and to the frame, if necessary.

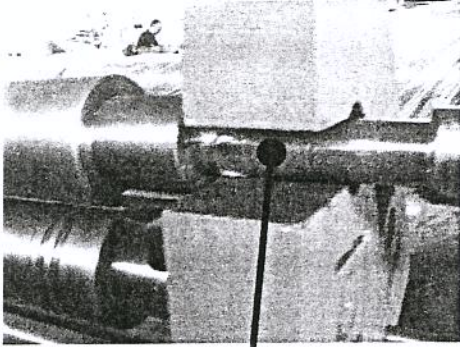

①



①

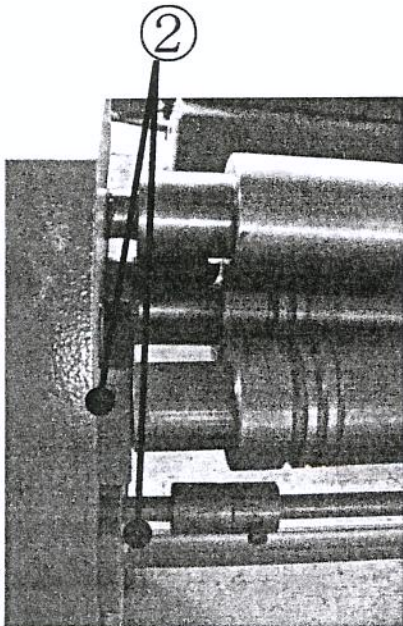

②

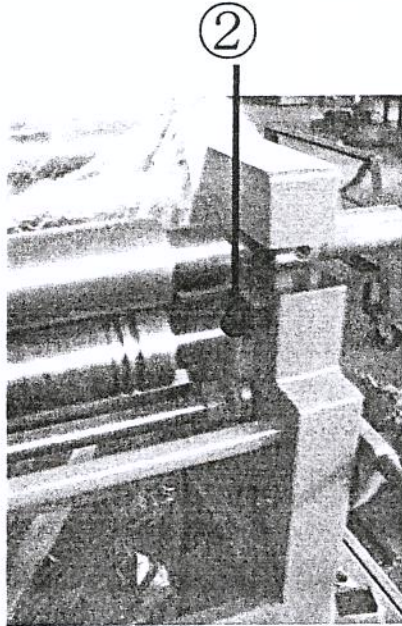

②

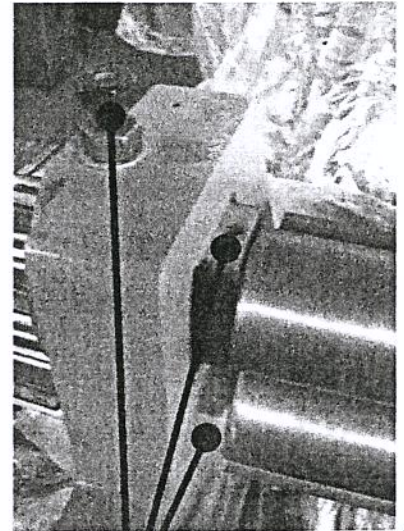

②



## PARTS LIST OF RM MODEL

<b>Assembly No</b>	<b>Part Identification</b>
1	Motor side cast frame
2	Open end side frame
3	Sheet metal frame
4	Motor gearbox group
5	Back roll
6	Top roll
7	Bottom roll
8	Bottom roll bushing
9	Back roll bushing
10	Top roll bushing
11a	Worm gear ( drive side )
11b	Worm gear ( motor side )
12	Back roll hand wheel
13	Bottom roll pinch handle
14	Top roll handle
15	Bottom roll pinch handle
16	Bottom roll shaft
17	Frame connection shaft
18a	Lifting rod with helix gear ( drive side )
18b	Lifting rod with helix gear ( drop end side )
19	Back roll lifting group – frame
20	Back roll shaft
21	Back roll coupling ( male – female )
22	Back roll coupling ( single )
23a	Cast ring ( drive side )
23b	Cast ring ( drop end side )
24	Top and bottom rolls drive gear
25	Big sprocket
26	Chain
27	Small sprocket
28	Tensioning group
29	Conical bending device

# Parts of The Machine

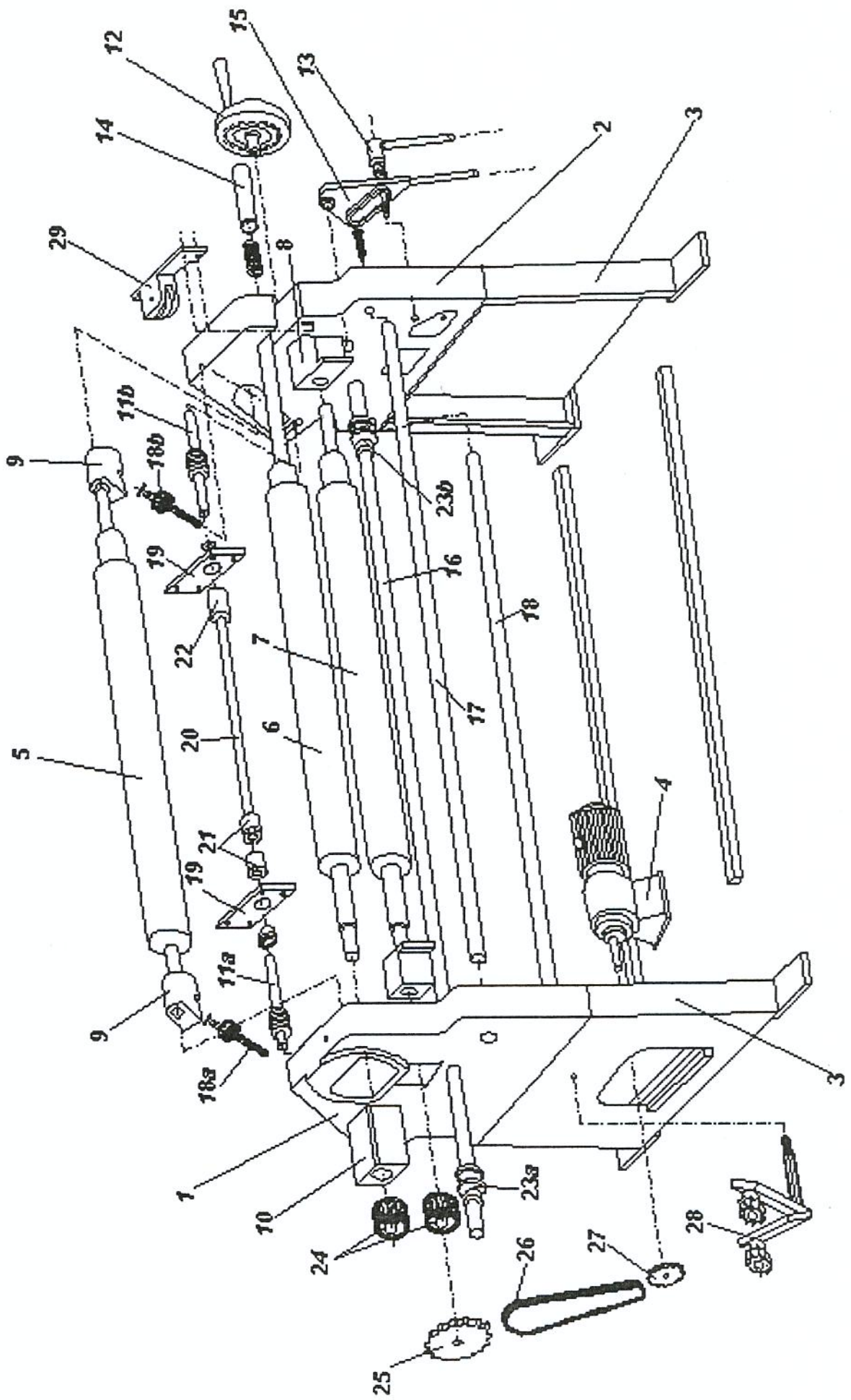

## RM ELECTRICAL PARTS LIST

NO	MATERIAL	CODE	PRODUCER	QUANTITY
1	Elektrical Cabinet 400/600/180 mm		KRAUS	1
2	Q1 Main Switch	KG10-B-T 203-01E	KRAUS & NAIMER	1
3	Q2 Motor Protection Overload Thermal relay	GV2-M10+GV2 AE11	TELEMECANIQUE	1
4	K1.K2 Motor Contacters	LC2 K0601 B7	TELEMECANIQUE	1
5	T1 Transformer 0/220/400/440/0/24/100VA		ETA	1
6	S1 Emergency Stop	XB4 BS245	TELEMECANIQUE	1
7	S2/H2 Start Button and Signal Lamp	XB4 BW 3365	TELEMECANIQUE	1
8	S3/H3 Stop Button and Signal Lamp	XB4 BW 3465	TELEMECANIQUE	1
9	H1 Power on Lamp	XB4 BV61	TELEMECANIQUE	1
10	RMT 130261-24-V AC-DC		KLEMSAN	1
11	Bridge Diode	KPBC35-10	KLEMSAN	1
12	F1.F2.F3 Fuse Holder and Glass Fuse	WSI-6	WEIDMÜLLER	3
13	Multi Poles Machine Plug-in	HDC-HA3-TOVL1/11P		1
14	Multi Poles Machine Plug	HDC-HA3-AVL		1
15	Q3 Speed Select Switch		TELEMECANIQUE	1



